

DIY KIT 141. Multi-Mode Timer

INTRODUCTION

No one can call themselves an electronics hobbyist unless they have built a timer. There are many tens of designs using a variety of new and sometimes old circuits. Witness the longest surviving IC of all, the 555, introduced over 20 years ago. Most timers have one characteristic – they only timed one thing; an egg timer, a delayed timer, a timeout timer, a flasher, a photographic timer, etc. As you will see these days are almost over.

The simplest (and cheapest) timers use an RC circuit for the timebase for example, our Kit 85. Whilst this is accurate enough for many applications (particularly those of several minutes delay) the testing and ‘adjusting’ required can be a nightmare. Imagine adjusting a 2 hour timer based on an RC circuit. Adjust ‘R’ (usually a trimpot) and start the timer. Wait around 2 hours to check the actual time delay. If necessary adjust the trimpot again and start over. Could take all day just to get it close to 2 hours!

Microcontrollers have changed all that. This kit contains **seven different timing modes** using only **ONE IC** and some support components on a **single-sided PCB**. This is a lot less than many single-mode traditional timers. The timing modes and delay ranges are selected by on-board DIP switches. Simply select the time delay you want and that’s it – no adjustment required.

You may wonder why we used an optocoupler for the trigger input. The answer is simple – using an optocoupler allows complete electrical isolation between the trigger source and the timer. This is important when dangerously high voltages are to be used for triggering the timer. The relay provides electrical isolation of the output as well.

A number of triggering options are available, ranging from a simple push button to electrically isolated voltage switching sources to taking the output from our counter & timer kits, K129 & K154. More on this later.

The kit is constructed on a single-sided PCB measuring 96 x 48 mm (3 3/4” x 1 7/8”). The kit requires a 9-to-12V DC power supply. A 12VDC wall adaptor rated at 300mA is suitable.

TIMER MODES

There are currently seven timer modes defined – mode 8 is unused at present. If you can think of another timer variation you would like (or even a completely different set of timing modes) then let us know. After all, it’s only a software change! Modes 6 and 7 were in fact suggested by users.

Please read the details of each of these timing modes **carefully**.

SPECIFICATIONS

Operating Voltage	12VDC (see text)
Trigger Voltage	6 – 81V (see text)
Trigger Current	5mA minimum (see text) 80mA maximum
Trigger Voltage Isolation	2500V
Trigger Pulse Width	20mS minimum
Relay Contact Rating	10A/240V AC/DC max.
Timing Modes	8 (see text)
Timing Ranges	1 – 255 seconds 10 – 2550 seconds 1 – 255 minutes 10 – 2550 minutes

Mode 1 - Instant On, Delayed Off, Level triggered

Trigger signal operates the relay and starts the timing cycle. The relay remains operated for the selected delay time then releases. Loss of trigger signal causes the timing cycle to stop immediately and the relay to release. The timer will then be ready for another trigger signal.

Mode 2 - Instant On, Delayed Off, Edge triggered

Same as Mode 0 except that loss of trigger signal does not affect the timing cycle. However, applying another trigger signal before the end of the timing cycle will restart the timer from zero. The effect is a “re-triggerable” timer.

Mode 3 - Delayed On

Trigger signal starts the timing cycle. At the end of the delay time the relay operates and stays operated until the trigger signal is removed or the timer is reset. Loss of trigger signal during the delay time aborts the timing cycle.

Mode 4 - Instant On and Hold, Delayed Off

Trigger signal operates the relay but does not start the timing cycle. The relays remains operated while the trigger signal is present. Loss of trigger signal starts timing cycle. Relay releases at end of delay time.

Mode 5 - Toggling

Trigger signal operates the relay for selected delay time. The relay then releases for the same delay time. This cycle continues until loss of trigger signal or reset.

Mode 6 - Instant On, Delayed Off, with Pause

Similar to Mode 0 – a trigger signal operates the relay and starts the timing cycle. However, loss of trigger signal causes the timing cycle to pause – the relay remains operated. Re-applying the trigger signal will re-start the delay time from where it was stopped. At the end of the delay time the relay releases.

DIY KIT 141. Multi-Mode Timer

Mode 7 – Delayed ON with Pause

Trigger signal starts the timing cycle. At the end of the delay time the relay operates for 2 seconds and the timing cycle starts again. Loss of trigger signal causes the timing cycle to pause. Re-applying the trigger signal re-starts the timing cycle from where it was stopped. Reset is the only way to exit this mode.

Mode 8 – Unused

NOTE: For each of the timer modes a reset signal will stop the timing cycle immediately and reset the timer, ready for another trigger signal. The timer is reset by connecting the RST input to the GND input.

ASSEMBLY INSTRUCTIONS

Use the component overlay on the PCB to place the components starting with the lowest height components first. Make sure that the diode, LED and electrolytic capacitors are inserted the right way around. A heatsink is fitted to the 7805 regulator using the supplied 3mm screw and nut to bolt the assembly to the PCB. Before tightening make sure the heatsink is not touching the relay.

There are two 5-way screw terminal blocks on the board. These are made by fitting together a 2-way and 3-way block, sliding the raised edge on the side of one block into the matching groove of the other block. The terminal block is inserted with the 'wire opening' to the outside of the PCB. They are rated 300V, 10A.

Do not insert any ICs yet.

TESTING

Apply power to the board. The RED power LED should be on and the relay released. Use a multimeter to measure the voltage across pins 20 (+) and 10(-) of the IC2 socket – it should read 5 volts. Use a short length of wire to connect IC2 socket pins 10 and 11. The relay should operate.

If all is well remove power and insert the ICs. Make sure no IC leads are 'bent under' as you insert them.

CIRCUIT DESCRIPTION

The heart of the circuit is IC2, an Atmel 89C2051 microcontroller. This is a 20-pin device using the popular 8051 core. It is pre-programmed with software to provide all the timing functions. A 12MHz crystal provides accurate timing and an easily divisible clock source for the internal hardware timers. The source code for this kit is not available.

Timing Accuracy: Crystals are accurate to +/- 100 ppm (parts per million). In this case the actual crystal frequency could vary by as much as 1200Hz either side of 12MHz - an error of 0.01% maximum. Over 42.5 hours (2550 minutes, the maximum delay time this kit can be programmed for) this amounts to a maximum

error of +/-0.255 minutes (+/- 15.3 seconds). **Try getting that with an RC circuit!**

The trigger signal is applied to the input of IC1, a 4N25 optocoupler. Using an optocoupler allows the trigger signal to be electrically isolated from the timer kit. This is especially useful if triggering the kit from high voltages such as mains, etc. Diode D2 protects the optocoupler's input from damage due to reverse voltages and resistor R1 provides current limiting.

The optocoupler output is normally high (5V) and goes low (0V) when triggered. With a load resistor of 10K (R3) we need a minimum current of 0.5mA to do drop the voltage 5 volts.

From the 4N25's datasheet, the input current required is 10 times the output current, in this case 5mA. This is the **minimum** input current required to trigger the timer. The voltage dropped across the optocoupler input diode, Vf, is typically 1V and remains fairly constant regardless of input current.

Therefore, the **minimum input voltage** necessary to trigger the timer is given by

$$\begin{aligned}V_{in} &= (I_{in} \times R1) + V_f \\ &= (5\text{mA} \times 1\text{K}) + 1\text{V} \\ &= 6\text{V}\end{aligned}$$

For lower input voltages reduce the value of R1.

The **maximum** optocoupler input current is 80mA. Using the same formula above, the **maximum input voltage** is $(80\text{mA} \times 1\text{K}) + 1\text{V} = 81\text{V}$. Of course you should allow for a safety margin, say 5 to 10mA.

For higher input voltages increase the value of R1 or add an external resistor.

Transistors Q1 and Q2 are used to operate the relay. At first glance you may wonder why TWO transistors were used when one would do. It's all to do with what happens on reset. On reset the microcontroller's I/O ports are configured as inputs (via internal hardware) and "float" high. If only one transistor was used the relay would be operated during reset. Of course the relay would be released after reset once the onboard software took over. However the relay would "flick" on momentarily – not what we want. Two transistors means we can use a low output to operate the relay and a high to release it - just right during reset!

Note that the relay is connected to the "V+" input supply. This reduces the current drain on the 7805 voltage regulator and also helps minimize any switching noise on the 5V supply to the microcontroller when the relay operates and releases. Diode D3 is the standard diode on a mechanical relay to prevent back EMF from damaging Q2 when the relay releases.

DIY KIT 141. Multi-Mode Timer

Power on reset is provided by R2 and C3. The 89C2051 microcontroller has an active high reset signal. Transistor Q3 allows the user to use a low level signal to reset the timer by connecting the RESET terminal on connector X1 to the GND terminal via a simple pushbutton switch.

A 7805 voltage regulator, IC3, provides 5V power for the kit. Diode D1 protects against reverse polarity connection of the input power and LED L1 indicates power on.

The timer requires a nominal 12VDC power supply. In practice this can be as low as 8V without affecting the 7805 voltage regulator. However the relay is rated at 12V so we need a 12V supply.

SETTING THE TIMER MODE

The timer mode is selected via SW3, a 3-way DIP switch.

MODE	SW3-1	SW3-2	SW3-3
1	ON	OFF	OFF
2	OFF	ON	OFF
3	ON	ON	OFF
4	OFF	OFF	ON
5	ON	OFF	ON
6	OFF	ON	ON
7	ON	ON	ON
8	OFF	OFF	OFF

SETTING THE TIME DELAY

Two sets of DIP switches are provided for setting the time delay, SW1 and SW2.

SW2 sets the base timing interval as follows:

	SW2 - 1	SW2 - 2
1 Second	OFF	OFF
10 Seconds	ON	OFF
1 Minute	OFF	ON
10 Minutes	ON	ON

SW1 sets the factor with which to multiply the base timing interval by to get the actual delay time. SW1 is binary weighted as follows:

SW1	8	7	6	5	4	3	2	1
Value	128	64	32	16	8	4	2	1

So, if SW1-8, SW1-3 and SW1-2 are ON the factor is 134 (128 + 4 + 2) and the delay time is 134 x base timing interval. So, if the base timing interval is 10 seconds the delay time is 134 x 10 seconds, or 1340 seconds, or 22.33 minutes, or 22 min 20 seconds with an accuracy of +/- 0.134 seconds, 0.01% of the delay.

If SW1-7 is also turned ON then this adds 64 to the delay factor making it 134 + 64, or 198.

The maximum delay factor is with all switches ON; 255.

All the switches in the OFF position is invalid and the timer will not function.

So, the timer's delay value is set by first selecting the timing interval using SW2 and then the actual delay factor using SW1.

The time delay is calculated by multiplying the base timing interval set by SW1 by the timing factor set by SW2.

As you can see there is overlap between the timing intervals. For example we can get a 10 minute delay by selecting a '1 minute' timing interval and setting the delay factor at 10 or selecting a '10 minute' timing interval and setting the delay factor at 1.

In summary, here are the time delays possible:

- 1 - 255 seconds in steps of 1 second
- 10 - 2550 seconds (42min 30sec) in 10sec steps
- 1 - 255 minutes in 1 minute steps
- 10 - 2550 minutes (42hr 30min) in 10 minute steps

Timing accuracy +/- 0.01%.

TRIGGERING THE TIMER

The timer's trigger input is the diode of an optocoupler IC with a series resistor to limit the current. The input trigger voltage needs to be in the range of 6 to 81 volts (refer to circuit description). How the trigger voltage is applied will depend on your application and the trigger source available.

Probably the most common device used for triggering the timer will be a simple 'make' contact either from a pushbutton switch or relay contact. This contact will be used to switch a voltage to the trigger input. We can use the timer's supply voltage for this. Connect the TRIG+ terminal to the VIN terminal and the switch or relay contact between the TRIG- and GND terminals (see Fig 1). Now when the contact closes the circuit path is complete and current flows, triggering the timer.

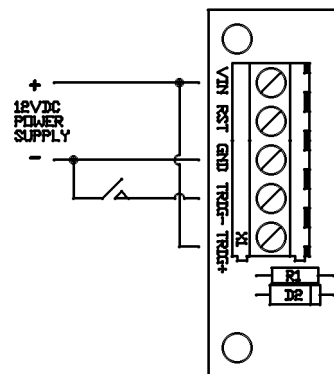

Fig 1. Pushbutton or relay contact triggering

In some cases an "open collector" style output will be used to trigger the kit. Open collector refers to the

DIY KIT 141. Multi-Mode Timer

output of a circuit or IC where an NPN transistor is used as the output driver. The transistor emitter pin is connected to the circuit 'ground' line and the collector left 'open'. When the transistor 'switches on' current can flow from the collector to the emitter. Think of it as an electronic version of the simple 'make' contact except that current will only flow in one direction.

Open collector outputs are often used in digital circuits (such as our K129 4-digit up/down counter and K154 4-digit presettable down counter) to switch relays, lamps, etc. Because the output is 'open' you can also connect multiple open collector outputs together with a common pull-up resistor or load. More than one output can 'go low' without causing damage to the others.

In the case where an open collector output is used to trigger the timer the same connection method as the simple 'make contact' above is used. In place of the 'make' contact the collector is connected to TRIG- and the emitter to GND (see Fig 2). Now when the trigger source 'switches on' its output transistor it will trigger the timer input. So the output of Kits 129 and 154 may be connected to Kit 141 in this way to trigger the timer when preset conditions in Kits 129 or 154 have been met.

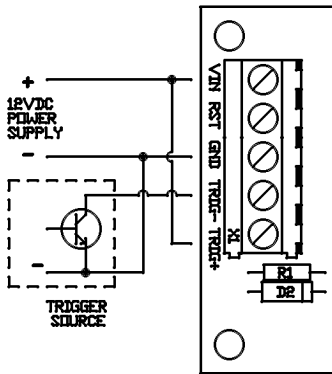

Fig 2. Open collector triggering

In the open collector triggering method the trigger source ground was connected to the timer ground. This is often referred to as 'commoning the ground lines' and is done to provide a common reference point between the two circuits. However this bypasses the electrical isolation on the timer's input because one side of the optocoupler's input is now connected to ground.

For complete electrical isolation the trigger source must drive the timer input without any connection to the timer's power supply. In Fig 3 the trigger source voltage, via either an internal or external switch, drives the timer input. There is NO electrical connection between the trigger source and the timer.

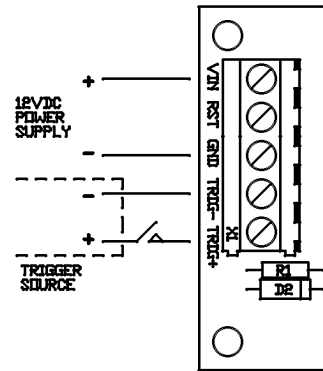

Fig 3. Electrically isolated triggering

INPUT CONNECTOR PINOUT

VIN	Input power positive, 12V nominal
RST	Active low reset input
GND	Input power negative (Ground)
TRIG-	Trigger input negative
TRIG+	Trigger input positive

OUTPUT CONNECTOR PINOUT

VOUT	Same as VIN
GND	Ground
NC	Normally Closed relay contact
C	Center (or common) relay contact
NO	Normally Open relay contact

VOUT and GND are provide as convenient connection points to power external devices.

The relay contact NC is normally connected to relay contact C when the relay is released (not operated). With the relay operated the C contact is connected to the NO contact.

IF IT DOES NOT WORK

Poor soldering ("dry joints") is the most common reason for the circuit not working. Check all soldered joints carefully under a good light. Re-solder any that look suspicious. Are all the components in their correct position on the PCB? Are the electrolytic capacitors and diodes the right way round? Are the ICs the right way around? Are any IC leads bent up under the IC body?

Is the regulator output = 5V?

Correction. R4 was 2K2 in the early schematics. Now changed to 4K7.

WEB ADDRESS & EMAIL

Information on other kits in the range is available from our Web page at <http://kitsrus.com>

For any technical problems or questions, contact the kit developer at frank@ozitronics.com

DIY KIT 141. Multi-Mode Timer

PARTS LIST – K141

Resistors (0.25W carbon)

1K brown black red.....	R6.....	1
1K5 brown green red	R1.....	1
2K2 red red red	R5.....	1
4K7 yellow violet red.....	R4.....	1
8K2 grey red red	R2.....	1
10K brown black orange	R3.....	1
10K SIL resnet, 10P9R, 'A' type, 103	RP1	1

Capacitors

22pF ceramic	C1,C2.....	2
100nF monobloc	C5,C6.....	2
10uF 16V electrolytic	C3.....	1
10uF 50V electrolytic	C4.....	1

Semiconductors

1N4004	D1,D2,D3.....	3
BC547 transistor, NPN	Q1,Q2	2
BC557 transistor, PNP.....	Q3	1
4N25 optocoupler	IC1	1
AT89C2051	IC2	1
ATMEL Microcontroller, preprogrammed		
7805, 5V regulator.....	IC3	1
LED, 5mm red	L1.....	1

Miscellaneous

Crystal, 12MHz.....	Y1.....	1
Relay, RWH-SH-112D.....	RL1	1
Screw terminal block, 3 way		2
Screw terminal block, 2 way		2
DIP switch, 2 way	SW2	1
DIP switch, 3 way	SW3	1
DIP switch, 8 way	SW1	1
IC socket, 6 pin	for IC1.....	1
IC socket, 20 pin	for IC2.....	1
Screw, 3 x 8mm, to fit heatsink to IC3.....		1
Nut, 3mm, to fit heatsink to IC3.....		1
PCB, K141		1

The source code for this kit is not available.

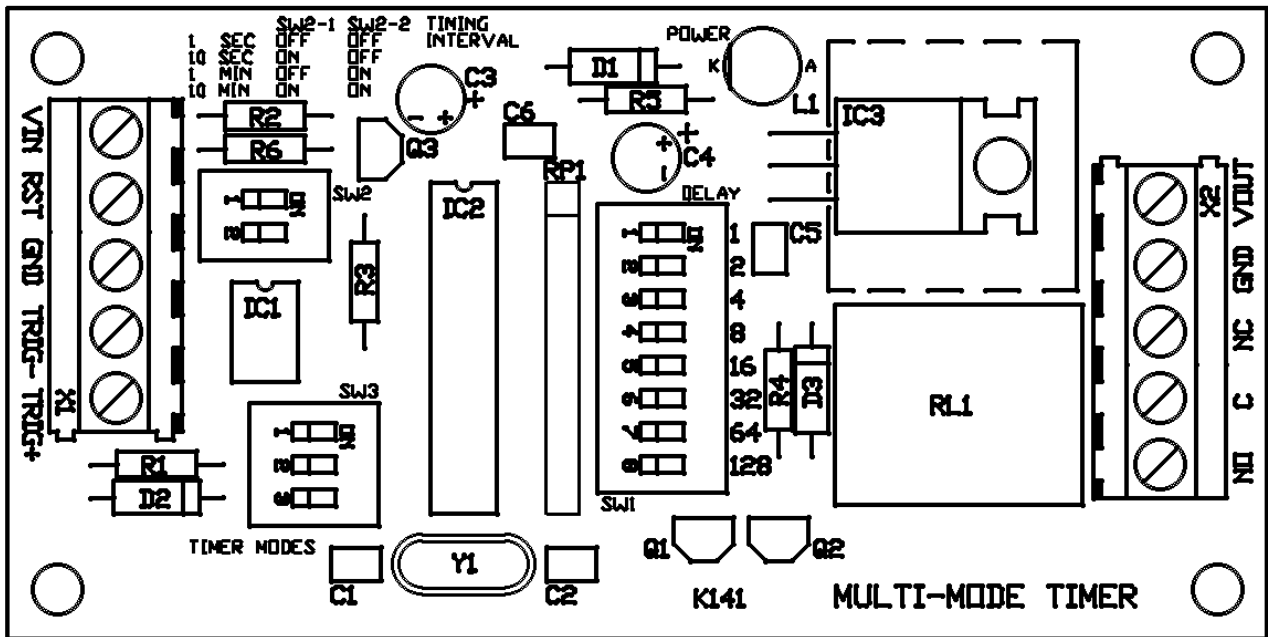

DIY KIT 141. Multi-Mode Timer

