

Kit 166V2. Bidirectional DC Motor Speed Controller

This kit controls the speed of a DC motor in both the forward and reverse direction. The range of control is from fully OFF to fully ON in both directions.

Normally, switches are used to change the direction of rotation of a DC motor. Change the polarity of the applied voltage and the motor spins the other way! However this has the disadvantage that a DPDT switch has to be added to change the polarity of the applied voltage. Now you have two things to control the motor – a direction switch as well as the speed control.

Also, it is not a good idea to suddenly reverse the voltage on a DC motor while it is spinning. It can cause a current surge that can burn out the speed controller. Not to mention any mechanical stress it can cause as well.

This kit overcomes both these problems. The direction and speed is controlled using a single potentiometer. Turning the pot in one direction causes the motor to start spinning. Turning the pot in the other direction causes the motor to spin in the opposite direction. The center position on the pot is OFF, forcing the motor to slow and stop before changing direction.

SPECIFICATIONS

Voltage: The kit and motor use the same power supply. Since the maximum operating voltage of the LM324 is **32VDC** then this is also the maximum voltage available to run the motor.

Current: The IRFZ44 MOSFET can handle 49A; the IRF4905 can handle 74A. However the PCB tracks that run from the MOSFET pins to the screw terminal block can only handle around 5A. This can be increased by soldering wire links across the PCB tracks. If you do then check that the MOSFETs don't get too hot – if so then bigger heatsinks will be required.

However **the real limiting** factor is how fast the MOSFETs are switched. Most of the power dissipation in a MOSFET occurs when in its linear region. Therefore the transition from ON to OFF (or OFF to ON) should be as fast as possible. MOSFETs have high gate capacitance so, to overcome this, they should be driven by a low impedance source. The gate drive circuitry used in this kit does not have a low enough impedance to do this.

The overall effect is that the maximum current this kit can handle is around 10 amps.

SPEED CONTROL OF DC MOTORS

Basically, there are three ways to vary the speed of DC motors:

1. With the use of mechanical gears to achieve the desired speed. This method is generally beyond the capability of most hobbyist home workshops.
2. Reducing the motor voltage with a series resistor. However this is inefficient (energy wasted in resistor) and reduces torque. The current drawn by the motor increases as the load on the motor increases. More current means a larger voltage drop across the series

resistor and therefore less voltage to the motor. The motor now tries to draw even more current, resulting in the motor "stalling".

3. By applying the full supply voltage to the motor in bursts or pulses, eliminating the series dropping effect. This is called **pulse width modulation (PWM)** and is the method used in this kit. Short pulses means the motor runs slowly; longer pulses make the motor run faster.

KIT ASSEMBLY

Check the components supplied in the kit against the parts list. In particular identify the IRFZ44 and IRF4905 MOSFETs. They look the same so do not get them mixed.

Before mounting any components to the PCB we need to assemble the MOSFETs to the heatsinks. Take an IRFZ44 and IRF4905 MOSFET and fit to either side of a heatsink. **Loosely** secure them together using the supplied 3mm screw and nut.

The MOSFETs need to be perfectly in line with the heatsink. The easiest way to do this is to mount the whole assembly onto the PCB, making sure that the heatsink pins and MOSFET leads fit into their respective holes. **Don't solder anything.**

Make sure the heatsink is sitting right down onto the PCB then tighten the screw and nut. Repeat for the other assembly then put them aside. They will be the last items fitted to the PCB.

It is recommended that components be inserted and soldered in the following order:

1. All the resistors and diodes, including zeners.
Note: When soldering Z2 please solder the 'cathode' end (near R13) on both sides of the board. It is marked with the words "SOLDER BOTH SIDES".
2. The 14 pin IC socket
3. Capacitor C3. This fits inside the IC socket. Make sure it doesn't poke up too high before soldering otherwise it will interfere with inserting the IC into the socket.
4. Transistors Q1 and Q2 and capacitor C1.
5. The electrolytic capacitor C2.
6. The 2-way screw terminal blocks. These should be joined together to make a 4-way block before inserting into the PCB.
7. Potentiometer P1
8. The previously assembled heatsink/MOSFET modules. Make sure they are fitted the right way around. The IRFZ44 should be facing towards the screw terminals. Remember to solder the heatsink pins to the PCB – this is necessary for mechanical strength.
9. Fit the LM324 to the IC socket.

Kit 166V2. Bidirectional DC Motor Speed Controller

There is one last thing to do. There is one via (pin through) on the PCB that needs to be filled with solder. It is just above Q6. It is marked with the words "FILL WITH SOLDER". **This must be done so that the via can handle the current.**

HOW IT WORKS (refer to schematic)

The circuit can be broken down in four parts:

1. Motor control – IC1:A
2. Triangle wave generator – IC1:B
3. Voltage comparators – IC1:C and D
4. Motor drive – Q3-6

Let's start with the motor drive section, based around MOSFETs Q3-6. Only two of these MOSFETs are on at any one time. When Q3 and Q6 are ON then current flows through the motor and it spins in one direction. When Q4 and Q5 are ON the current flow is reversed and the motor spins in the opposite direction. IC1:C and IC1:D control which MOSFETs are turned on.

Zener diodes Z1-4 limit the gate-source voltage of the MOSFETs to 16 volts. This protects the MOSFETs when powering the kit from higher voltages ie. 24V battery.

Opamps IC1:C and IC1:D are configured as voltage comparators. The reference voltage that each triggers at is derived from the resistor voltage divider of R6, R7 and R8. Note that the reference voltage for IC1:D is connected to the '+' input but for IC1:C it is connected to the '-' input. Therefore IC1:D is triggered by a voltage greater than its reference whereas IC1:C is triggered by a voltage less than its reference.

Opamp IC1:B is set up as a triangle wave generator and provides the trigger signal for the voltage comparators. The frequency is approximately the inverse of the time constant of R5 and C1 – 270Hz for the values used. Reducing R5 or C1 will increase the frequency; increasing either will decrease the frequency.

The peak-to-peak output level of the triangle wave is less than the difference between the two voltage references. Therefore it is impossible for both comparators to be triggered simultaneously. Otherwise all four MOSFETs would conduct, causing a short circuit that would destroy them.

The triangle waveform is centered around a DC offset voltage. Raising or lowering the offset voltage changes the DC position of the triangle wave accordingly. Shifting the triangle wave up causes comparator IC1:D to trigger; lowering it causes comparator IC1:C to trigger. When the voltage level of the triangle wave is between the two voltage references then neither comparator is triggered.

The DC offset voltage is controlled by the potentiometer P1 via IC1:A, which is configured as a voltage follower. This provides a low output impedance voltage source, making the DC offset voltage less susceptible to the loading effect of IC1:B. As the 'pot' is turned the DC

offset voltage changes, either up or down depending on the direction the pot is turned.

Diode D3 provides reverse polarity protection for the controller. Resistor R15 and capacitor C2 are a simple low pass filter. This is designed to filter out any voltage spikes caused by the MOSFETs as they switch to supply power to the motor.

HOW TO CONNECT

The motor connects to the **M1** and **M2** terminals.

The power supply connects to the **V+** and **GND** terminals.

TROUBLESHOOTING

Most faults are due to assembly or soldering errors. Verify that you have the right components in the right place.

Inspect your work carefully under a bright light. The solder joints should have a 'shiny' look about them. Check that there are no solder bridges between adjacent pads.

Check that no IC pins are bent up under the body of the IC. This can sometimes happen when inserting ICs into sockets.

Kit 166V2. Bidirectional DC Motor Speed Controller

PARTS LIST – K166V2

Resistors (0.25W carbon film unless specified)

100R.....	R15.....	1
4K7.....	R9,14.....	2
10K.....	R2,7,10,11,12,13.....	6

Note:

R10,11,12,13 shown as '1K' on PCB overlay – error.

12K.....	R8.....	1
33K.....	R6.....	1
47K.....	R3.....	1
100K.....	R1.....	1
220K.....	R4.....	1
470K.....	R5.....	1
100K potentiometer.....	P1.....	1
PCB mounting		

Capacitors

10nF 63V box poly.....	C1.....	1
100nF mono, 0.1".....	C3.....	1
100uF 63V electrolytic.....	C2.....	1

Semiconductors

1N4004.....	D3.....	1
1N4148.....	D1,2.....	2
16V 400mW zener.....	Z1,2,3,4.....	4
BC547 transistor.....	Q1,2.....	2
IRF4905.....	Q3,5.....	2

P-channel Power MOSFET

IRFZ44.....	Q4,6.....	2
-------------	-----------	---

N-channel Power MOSFET

LM324.....	IC1.....	1
------------	----------	---

Quad opamp

Miscellaneous

IC socket, 14 pin, for IC1.....	1
Screw terminal block, 2 way.....	2
(joined to make a 4-way block)	
Heatsinks for MOSFETs Q1-4.....	2
Screw, 3 x 8mm.....	2
Nuts, 3mm.....	2
K166V2 PCB.....	1

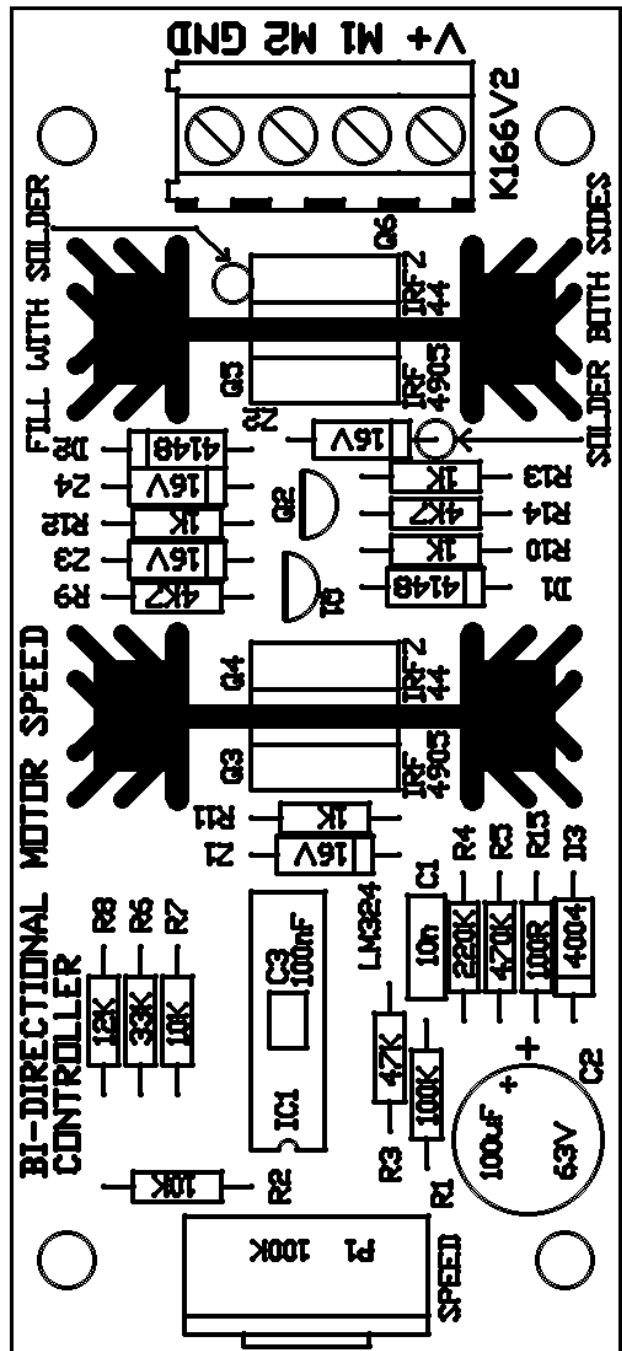

DATASHEETS

IRFZ44, IRF4905 MOSFETs - www.irf.com

LM324 quad opamp - www.national.com

CONTACT DETAILS

For our full range of kits see our website at

<http://www.kitsrus.com>

Kit developer: <http://www.ozitronics.com/>

NOTE:

Resistors R10-13 are shown as '1K' on the PCB overlay. They are in fact 10K as per the schematic and parts list.

