

KIT 61. GENERAL PURPOSE 3 1/2 DIGIT LED PANEL METER

In Kit 34 we presented a general purpose 3 1/2 digit panel meter (DPM) using the 7106 IC and an LCD. The sister chip to the 7106 is the 7107 which uses an LED display for its output. There are two advantages to using the 7107 over the 7106. The first is that because it is powered by +5V and -5V it can accept inputs in the range +4V to -4V. A second advantage is when a digital reading of zero is desired for a V_{IN} not equal to zero as, for example, temperature and weighing systems with a variable tare. Both the offset voltage and the transducer voltage can be conveniently input directly to the 7107. In 7106 systems null calibration requires additional electronics off-chip.

Kit 61 has been designed as a versatile 3 1/2 digit panel meter with these considerations in mind. Also in this Kit we have used small, monoblock capacitors rather than the much bigger mylar or metallized types. This saves space as well as making the meter look better. Some components are under the IC to save even more space.

Voltage is the most frequently measured electrical quantity. In DPM's to measure temperature, current, wind speed, resistance, lux etc., what is actually being measured is voltage. After calibrating the meter for its particular purpose the voltage measured will give an accurate digital reading of the analog quantity being measured.

Digital displays have many advantages over analog meters which use a pointer and moving coil. Firstly they are easier to read especially by unskilled labour. In the majority of applications it is better that the value displayed is exactly the value being measured, for example, 13.6V. To use an analog display with its many graduated scales (some going up and others going down) and switches requires considerable practice. But a simple LED display which reads '13.6' can be understood by everyone.

Second, DPM built using the 7107 are physically stronger and more robust than analog meters because they have no moving parts. Thirdly, for the manufacturer the assembly of the complete DPM unit can be done by relatively unskilled labour in third world countries. Fourthly, the 7107 by its very nature can be adapted to so many uses at such a low cost that it has actually created markets for itself. All of these factors add up to a better, cheaper product which everyone can afford.

Two circuit boards have been used. The 4 LED displays mount on one board which is soldered to the mother board at right angles. This allows low profile end viewing.

The kit is constructed on single-sided printed circuit boards. Protel Autotrax & Schematic were used.

ASSEMBLY INSTRUCTIONS

Check the components in the Kit against the Component listing. Make sure you identify every component.

Display PCB. Fit the 4 LED displays to the display PCB by following the overlay and solder. Do **not attach** to the mother board yet. That will be the last thing to do.

Main PCB. It is easiest to solder the lowest height components first - the diodes, resistors monoblock capacitors and the single link. Use some of the leads cut off from the resistors to attach four wires coming out of the TEST, REF HI & REF LO pads. These will be used later. **Note** that R5 R6 R7 **stand up** on the board. The link and 3 of the components fit **under** the 7107 IC. Then attach the IC sockets, switches and remaining components. Watch the orientation of the electrolytic capacitors and the two IC's. The two terminal blocks which are next to each other slide together in a tongue & groove arrangement. Put them together before soldering them. We have supplied resistor RY1 of 10M resistance. Because the input impedance of the 7107 is so high this will make sure that the display does not pick up stray charge and will calibrate correctly when you first turn it on. Leave this resistor in place except when you use the input voltage divider as explained below.

The last step in construction is to attach the two PCB's together using the 27 pin post header connector. The short, 90° pins fit into the top of the mother board. Solder it into place first. Then fit on the display board to the long straight pins. Make sure you get the display board the correct way around. Look for the V+ and the G pins. These are marked on both PCB's. On the display board it is marked on the bottom side under the solder mask.) Make sure you match them up: V+ to V+, G to G.

Connect +5V to the board and turn it on. Put the switch in the Normal position. When the TEST pin 37 of the 7107 is connected to V_{CC} then the display should read -1888. You can easily do this by touching together the two wires you previously soldered into the two pads at TEST. This will tell you that the IC and the display are working correctly.

WHAT TO DO IF IT DOES NOT WORK

Poor soldering is the most likely reason. Check all solder joints carefully under a good light. Next check that all components are in their correct position on the PCB. Thirdly, follow the track with a voltmeter to check the potential differences at various parts of the circuit. Check that -5V is going to pin 26 of the 7107.

CIRCUIT DESCRIPTION

As you can see from the schematic on the previous page most of the connections are between the 7107 and the LED's. The 7107 contains a number of inputs which can be varied to do different things. Of prime importance is the reference voltage, V_{REF} , which is set by the 10K trimpot and R3. These will be discussed below.

-5V Generation. With the addition of only two capacitors the 7660 IC performs the complete supply voltage conversion from positive to negative for an input range of 1.5 to 10V, resulting in complementary output voltages of -1.5V to -10V.

KIT 61. GENERAL PURPOSE 3 1/2 DIGIT LED PANEL METER

$$V_{IN} = 2 \times V_{REF}$$

7107. The heart of the meter is the a/d converter built into the 7107. It uses a dual slope conversion technique. It relies on the charging and discharging of an integrating capacitor and having a counter count when the capacitor voltage is above a set value. Since the capacitor discharge is linear the counter reading is proportional to the input voltage. There are three phases to the process:

Phase 1. Auto Zero. The autozero capacitor is charged to the integrators offset voltage. This voltage is subtracted from the input signal during phase 2. The integrator thus appears to have zero offset voltage.

Phase 2. Signal Integrate. The signal input is averaged for 1000 clock pulses.

Phase 3. Reference Integrate. Input low is internally connected to Common (which may be an offset voltage.) VREF is averaged back to either zero volts or the offset voltage over another 1000 clock pulses. The number of clock pulses counted to return to this value is a digital measure of V_{IN} .

System Timing. This is determined by the components connected to pins 38, 39 & 40. Values are unchanged for all ranges measured. The internal oscillator runs at 48kHz, or 3 readings per second.

Decimal Point. A jumper selects the decimal point position in the displays.

Analog Section. C1 is the reference capacitor and is unchanged for all ranges measured. IN LO is tied to the analog COMMON pin 32 by the Normal position of the switch except when an Offset voltage is input. See below.

The integration capacitor C5 is suitable for all ranges measured but the value of the integration resistor R1 should be increased to 470K for a V_{REF} of 1V.

Auto-Zero Capacitor. This is C4 connected to pin 29. It has some influence on the noise of the system and recovery from overload input. On the 2V scale a 0.047uF capacitor may give better results.

Voltage Measurement. Since the maximum value which can be displayed is 1999, voltmeters with full scale readings of 199.9mV, 1.999V, 19.99V etc. can be made. The user must decide their own need. Then a reference voltage and maybe an input attenuator must be selected.

To use the meter to measure 0 - 199.9mV the trimpot is adjusted so that the reference voltage between pins 35 & 36 is 100mV. And to set the meter for 0 - 1.999V, V_{REF} must be set to 1.0V. Measuring higher voltages and non-standard voltages will be discussed below.

The relationship between full scale input voltage and the reference voltage is:

And V_{REF} must be in the range 100mV to 1.0V.

Components supplied in this Kit are for V_{REF} of 100mV. For a V_{REF} of 1V two components should be changed (as mentioned above) to maintain sensitivity and recovery from over-voltage. The 10K trim pot and resistor R3 will allow adjustment for either value, and for intermediate values when required (discussed below.) In the following discussion we will assume that we are using a V_{REF} of 100mV.

Calibration is done by attaching a (preferably digital) multimeter to REF HI and REF LO and adjusting the trimpot to read 100 mV. This is why wires were put into these pads during construction. Now the meter is calibrated to read 0 - 199.9mV.

Voltage Divider. To measure voltage greater than 0.2V an input voltage divider is required. See the figure below. This is the purpose of the space for 4 resistors on the main circuit board. The general relation for full scale sensitivity is now:

$$V_{IN} (\text{full scale}) = 2V_{REF} \times R_Y / (R_X + R_Y)$$

For example, a 0 - 20V range (when V_{REF} is 0.1V) can be obtained using a 100:1 voltage divider. This can be done by making $R_X = 1M$ and $R_Y = 10K$. The decimal point jumper is placed at position '2' so a full scale display of 19.99V is indicated. Similarly, a 0 - 200V range can be obtained with $R_X = 1M$ and $R_Y = 1K$.

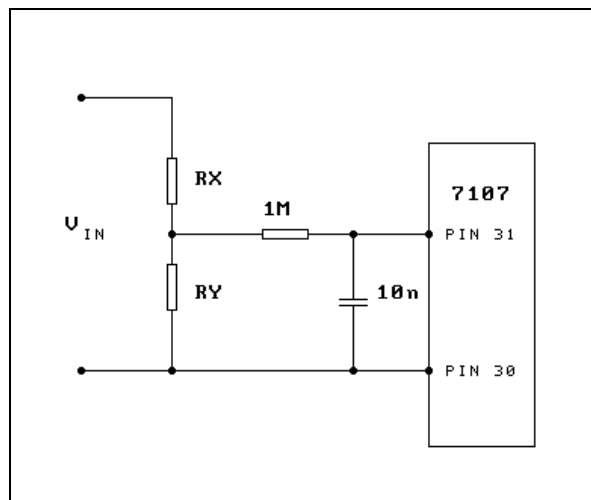

Figure 1

If V_{REF} is 1V a similar pattern of voltage divider resistors can be determined. Remember that if no input divider is used to put the 10M resistor back in RY1 across the input leads

Input an Offset Voltage. A major advantage of a 7107-based meter over a 7106-based meter is that an offset voltage may be read directly by the 7107. The same function with a 7106 meter requires additional electronics

KIT 61. GENERAL PURPOSE 3 1/2 DIGIT LED PANEL METER

to be built. To use the Offset input first move the switch the 'Use Offset' position. The offset voltage is input to pin 32, Offset, and pin 30, In Lo, while the transducer is connected as normal using Input 2 and Input 3. Refer to the schematic.

Non-standard Voltage Input. In many applications it is required that the output of a transducer is converted by a scale factor into some meaningful result. For example, a load cell of a weighing system may have an output voltage of 0.682V when it has 2.0 Kg weight on it. You want the meter to read the range 0 - 1.99 Kg directly.

It is an easy matter to adjust V_{REF} to 0.341V (half the output voltage), put the decimal point in the correct position by moving the jumper and the panel meter now reads off 0 - 1.99 Kg directly from the display.

Current Measurement. Currents up to 2A can be easily measured using the space on the board for a 5W shunt resistor, R. The current is converted into a voltage by the shunt resistor. The voltage divider resistors RX and RY (including RY1) are not used. The principal is shown in Figure 2 below.

If $R = 0.1$ ohms then 200mV will be developed when the current through it is 2A. This voltage is applied to the meter which is set up for the 200mV range. (That is, V_{REF} is set to 100mV.) Power dissipation at the maximum reading is I^2R which is 0.4W, well within the 5W rating of the resistor. See Table below.

To measure a full scale of 200mA then R should be 1.0 ohms in order to generate 200mV input to the meter. For a 20 mA meter then $R = 10$ ohms. Note that because of wide tolerances in the shunt resistors it may be necessary to adjust the reference voltage in order to get the correct reading. So further adjustment of V_{REF} using a known current may be required.

WHAT TO LEARN FROM THIS KIT

The Kit shows how much of electronics today can be contained in a single chip. Commercial low to medium cost digital multimeters are nothing more than this kit, some switches and passive components and a plastic case. The main reason today for the failure of meters is more likely due to switch contact and mechanical failure rather than failure of the electronics itself.

COMPONENTS		
Resistors 5%, 1/4W:		
47K	R1 yellow violet orange	1
100K	R2 brown black yellow	1
15K	R3 brown green orange	1
1M	R4 brown black green	1
470R	R5 R6 R7 yellow violet brown	3
10M	RY1 brown black blue	1
10K	trimpot 103	1
1N4148	diode	2
Capacitors:		
0.1uF	104 monoblok C1	1
0.01uF	103 monoblok C2	1
100pF	101 monoblok C3	1
0.47uF	474 monoblok C4	1
0.22uF	224 monoblok C5	1
100uF	16V minicap C6	1
10uF	mini ecap C7 C8	2
LED	CA display KW1-561ASA	4
7107	IC1	1
7660	IC2	1
40 pin	IC socket	1
8 pin	IC socket	1
K61	main PCB	1
K61	display PCB	1
2 pole	terminal block	3
SPDT	pcb-mounted switch	2
Jumper		1
3 post	dual row header	1
27 pin	single-in-line 90° header	1

See our kit range at <http://www.kitsrus.com>

For more technical information about using the 7106 and 7107 IC's go to

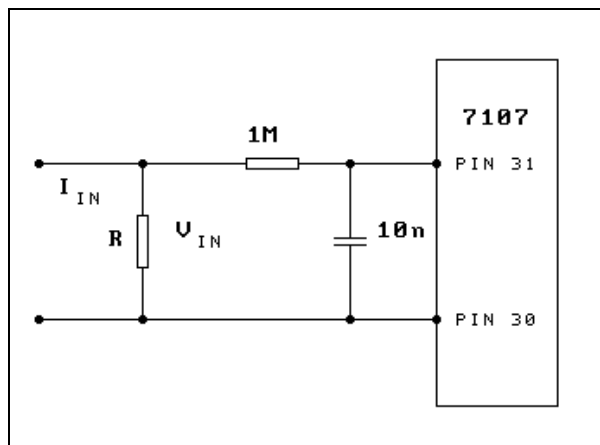

Figure 2

<http://www.intersil.com/data/fn/fn3082.pdf>

<http://www.intersil.com/data/an/an023.pdf>

KIT 61. GENERAL PURPOSE 3 1/2 DIGIT LED PANEL METER

