3W Power LED with Heat Sink Series

(Care should be take to the heat release matter when using this High Power LED)

Color	With Heat Sink Part No:	Without Heat Sink Part No:
White	WW-E203WH1-W1	WW-E203WH0-W1
Warm White	WW-E203TH1-W1	WW-E203TH0-W1
Red	WW-E203RH1-B8	WW-E203RH0-B8
Green	WW-E203GH1-W4	WW-E203GH0-W4
Blue	WW-E203BH1-B8	WW-E203BH0-B8
Yellow	WW-E203YH1-B8	WW-E203YH0-B8

Designed for high current operation and high flux output applications. Furthermore, its thermal management characteristic is better than other LED Solutions. By package SMD design and good thermal emission material. According to these advantages, it enables to apply various lighting applications and design solution, automotive lighting, and large size LCD backlight etc.

Features

- Super high Flux output and high Luminance
- Very long operating life (up to 50k hours)
- Designed for high current operation
- Low thermal resistance
- SMT solder bility
- Lead Free product
- RoHS compliant
- No UV
- Superior ESD protection

Application

- Mobile phone flash
- Automotive interior / exterior lighting
- Automotive signal lighting
- Automotive forward lighting
- General Torch
- Architectural lighting
- LCD TV / Monitor Backlight
- Projector light source
- Traffic signals
- Task lighting
- Decorative / Pathway lighting
- Remote / Solar powered lighting
- Household appliances

Outline Dimensions

Dome Type

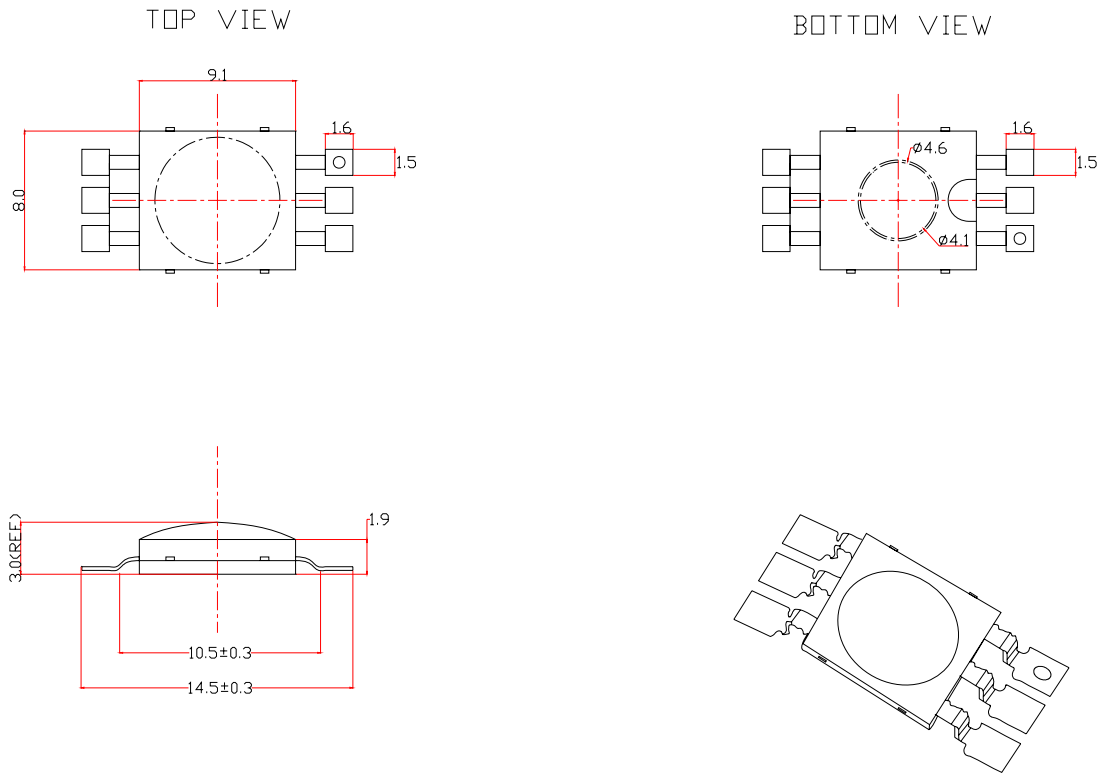

Notes:

1. All dimensions are in millimeter.
2. The anode side of the device is denoted by a hole in the lead frame. Electrical insulation between the case and the board is required-slug of device is not electrically neutral. Do not electrically connect either the anode or cathode to the slug.
3. All dimensions without tolerances are for reference only.
4. Caution must be used in handing this device to avoid damage to the lens surfaces that will reduce optical efficiency.

Characteristics for 3W Power LED

Electro-Optical characteristics at IF=1A, TA=25°C

1. Pure White

Parameter	Symbol	Value			Unit
		Min	Typ	Max	
Luminous Flux	Φ_v	130	170	-	lm
Correlated Color Temperature	CCT	-	6000	-	K
CRI	R_a	65	70	-	-
Forward Voltage	V_F	-	3.5	4.5	V
View Angle	2 Θ 1/2	110			deg.

2. Warm White

Parameter	Symbol	Value			Unit
		Min	Typ	Max	
Luminous Flux	Φ_v	100	130	-	lm
Correlated Color Temperature	CCT	-	3000	-	K
CRI	R_a	60	65	-	-
Forward Voltage	V_F	-	3.5	4.5	V
View Angle	2 Θ 1/2	110			deg.

3. Red

Parameter	Symbol	Value			Unit
		Min	Typ	Max	
Luminous Flux	Φ_v	27	36	-	lm
Dominant Wavelength	λ	620	-	630	nm
Forward Voltage	V_F	-	2.2	2.8	V
View Angle	2 Θ 1/2	90			deg.

4. Green

Parameter	Symbol	Value			Unit
		Min	Typ	Max	
Luminous Flux	Φ_v	130	170	-	lm
Dominant Wavelength	λ	515	-	525	nm
Forward Voltage	V_F	-	3.5	4.5	V
View Angle	2 Θ 1/2	140			deg.

5. Blue

Parameter	Symbol	Value			Unit
		Min	Typ	Max	
Luminous Flux	Φ_v	27	36	-	lm
Dominant Wavelength	λ	460	-	470	nm
Forward Voltage	V_F	-	3.5	4.5	V
View Angle	2 Θ 1/2	110			deg.

6. Yellow

Parameter	Symbol	Value			Unit
		Min	Typ	Max	
Luminous Flux	Φ_v	27	36	-	lm
Dominant Wavelength	λ	585	-	595	nm
Forward Voltage	V_F	-	2.2	2.8	V
View Angle	$2\theta_{1/2}$	90			deg.

Absolute Maximum Ratings

Parameter	Symbol	Value	Unit
Forward Current	I_F	1	A
Power Dissipation	P_D	4.8	W
Junction Temperature	T_j	125	°C
Operating Temperature	T_{opr}	-30~+85	°C
Storage Temperature	T_{stg}	-40~+120	°C

* Notes :

[1] WW maintains a tolerance of $\pm 10\%$ on flux and power measurements.

[2] CCT $\pm 5\%$ tester tolerance and $\lambda_d \pm 1\text{nm}$

[3] A tolerance of $\pm 0.1\text{V}$ on forward voltage measurements

[4] View Angle maintains a tolerance of $\pm 20^\circ$

* Caution

1. Please do not drive at rated current more than 5 sec. without proper heat sink

**White color spectrum, TA=25°C
Pure White**

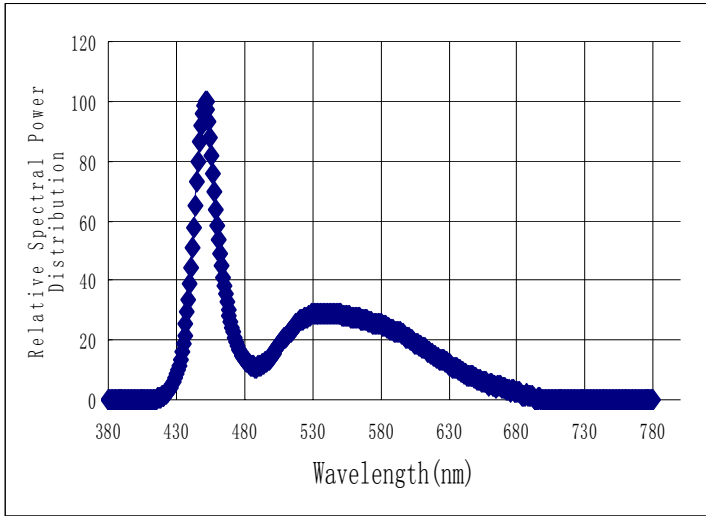

Pure White

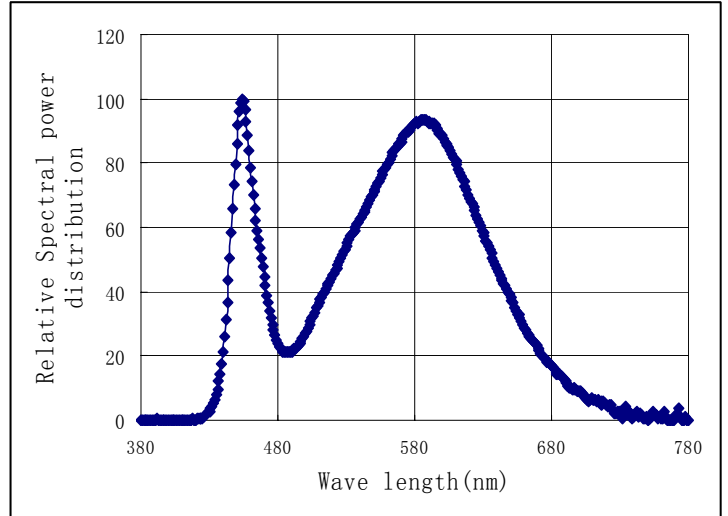

**Relative Light Output vs. Junction Temperature
(Pure/Warm white R/G/B/Y) at IF=1000mA, TA=25°C**

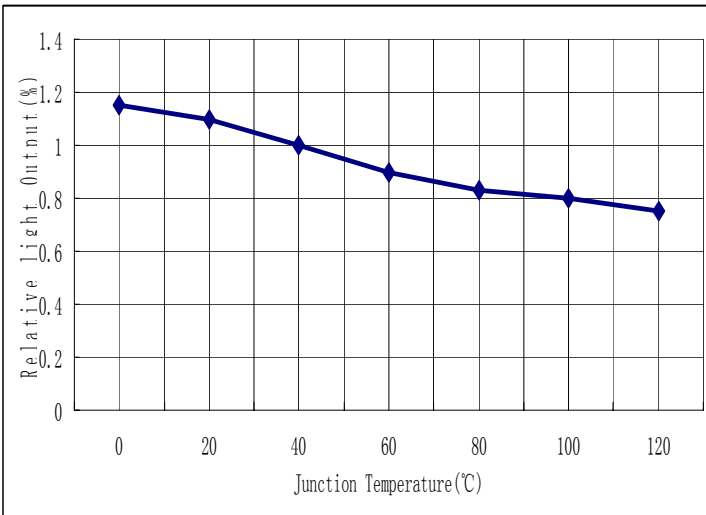

**Forward Voltage vs. Forward Current, TA=25°C
(Pure/Warm white G/B)**

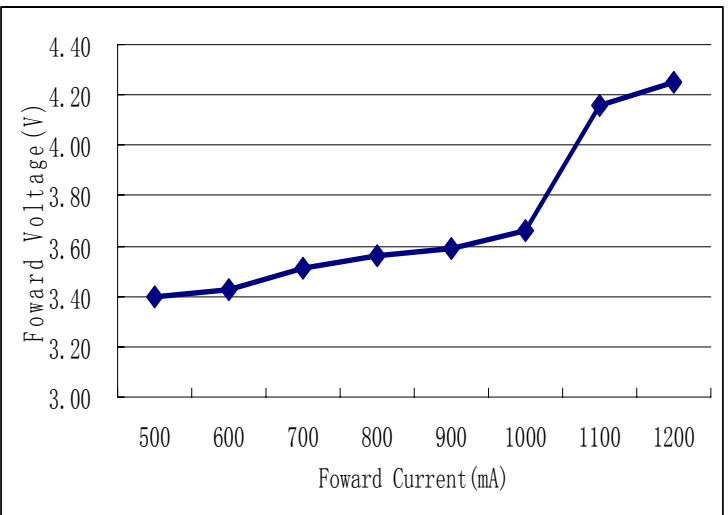

Typical Radiation(Pure white,Warm white)

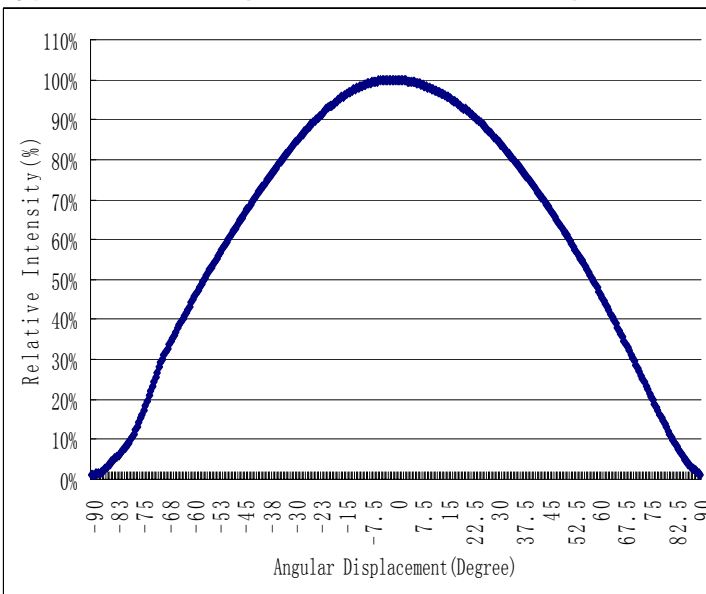

Typical Radiation(Red Blue Green Yellow)

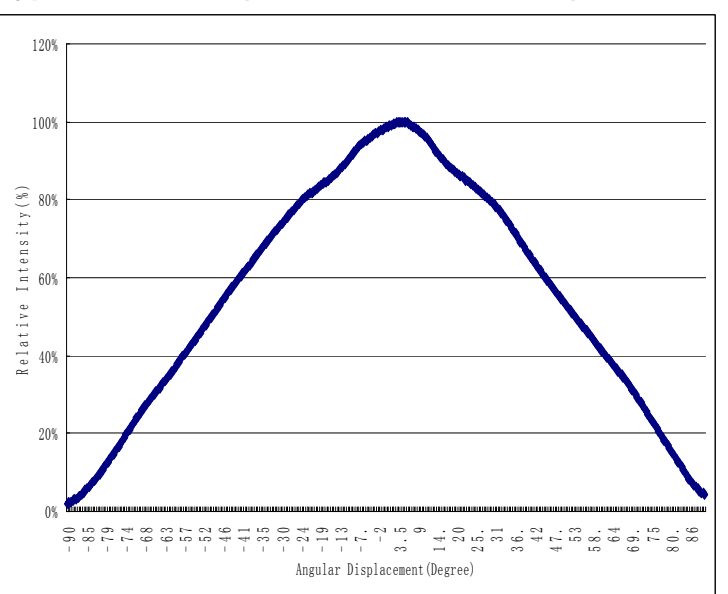

**Forward Current VS Chromaticity Coordinate:
TA=25°C (Pure white)**

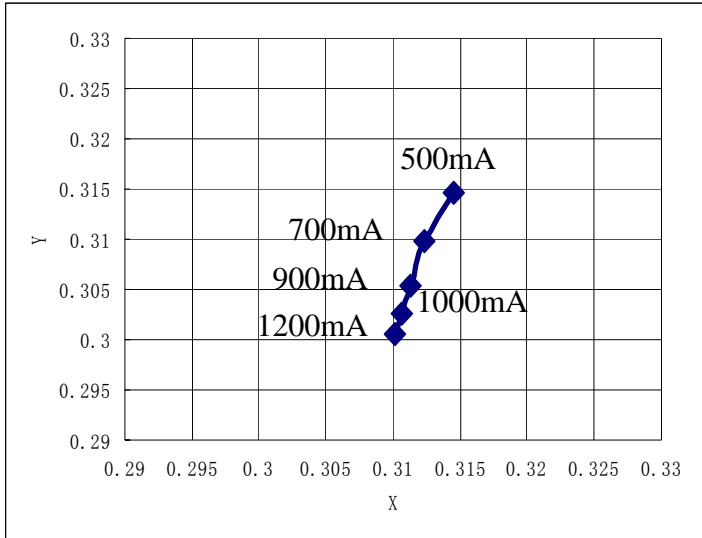

**Forward Current VS Chromaticity Coordinate:
TA=25°C (Warm white)**

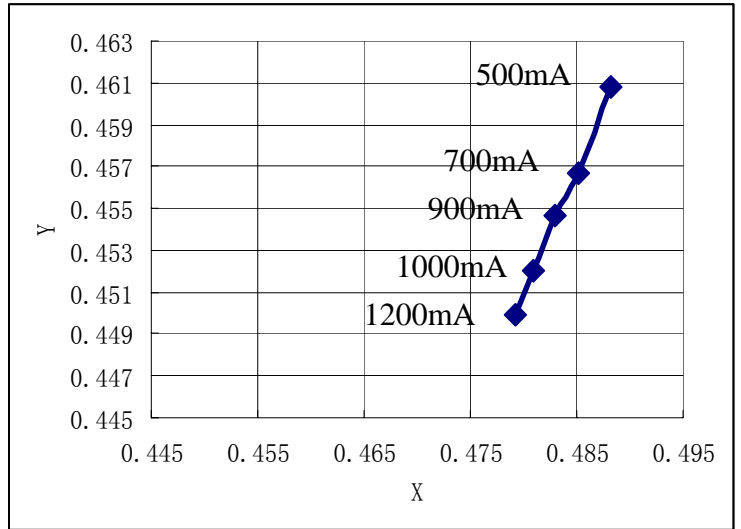

Ambient Temperature. VS Allowable Forward Current(Pure white, Warm white)

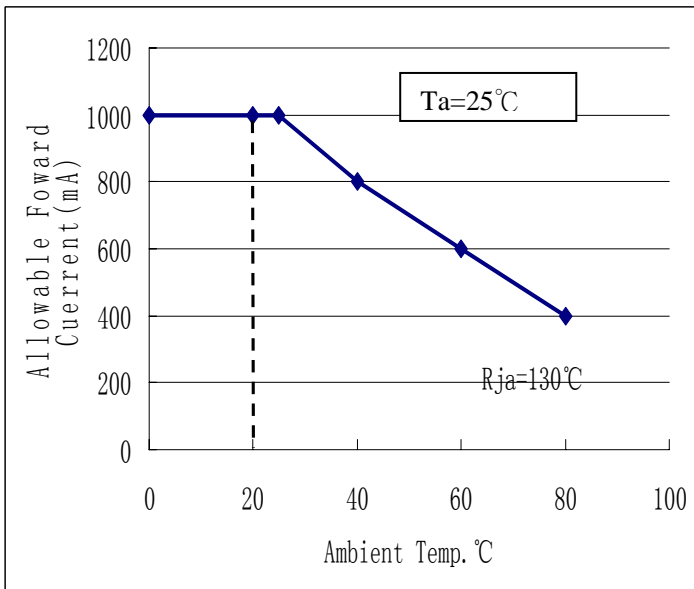

Forward Current VS Relative Luminosity(Pure/Warm white)

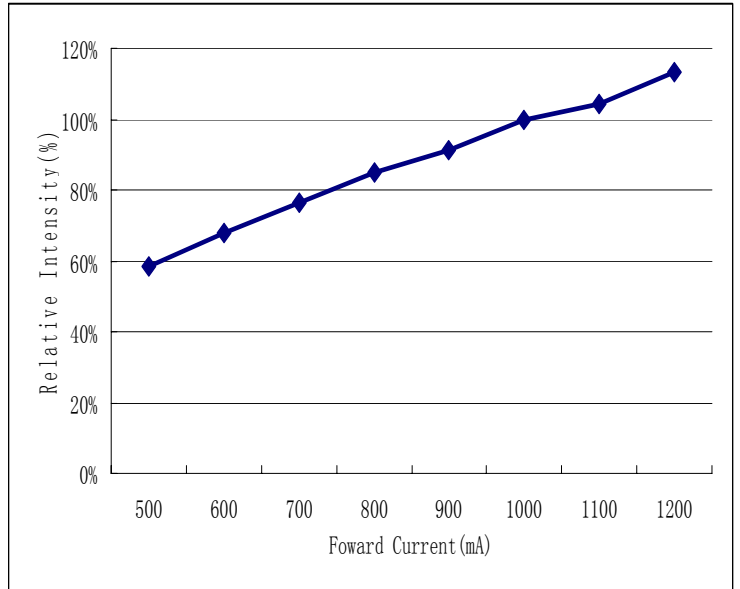

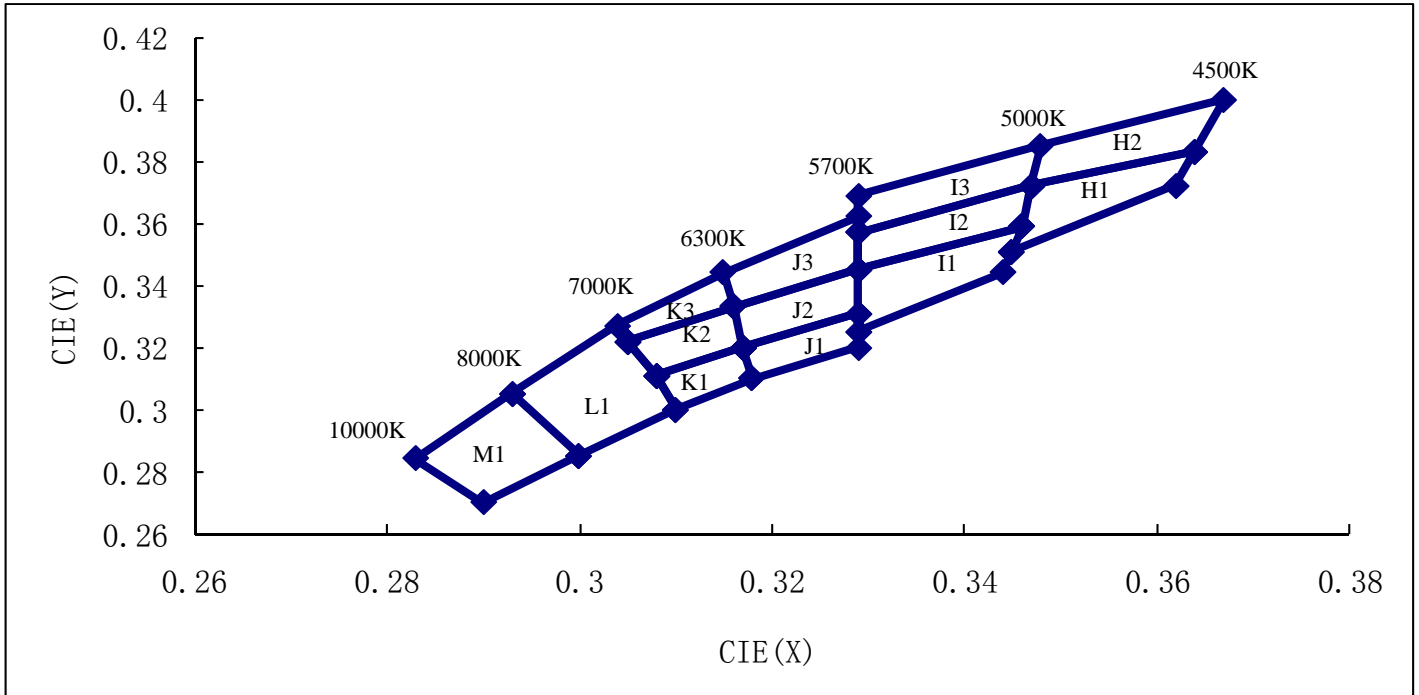

BIN	CHR-X	CHR-Y	TC(K)	BIN	CHR-X	CHR-Y	TC(K)
M1	0.293	0.305	9000	J1	0.329	0.331	6050
	0.283	0.284			0.317	0.32	
	0.29	0.27			0.318	0.31	
	0.3	0.285			0.329	0.32	
L1	0.304	0.327	7500	I3	0.329	0.325	5350
	0.293	0.305			0.348	0.385	
	0.3	0.285			0.329	0.369	
	0.31	0.3			0.329	0.362	
	0.308	0.311			0.329	0.357	
	0.305	0.322			0.347	0.372	
K3	0.315	0.344	6700	I2	0.347	0.372	5350
	0.304	0.327			0.329	0.357	
	0.305	0.322			0.329	0.345	
	0.316	0.333			0.346	0.359	
K2	0.316	0.333	6700	I1	0.346	0.359	5350
	0.305	0.322			0.329	0.345	
	0.308	0.311			0.329	0.331	
	0.317	0.32			0.329	0.325	
K1	0.317	0.32	6700	H2	0.344	0.344	4800
	0.308	0.311			0.345	0.351	
	0.31	0.3			0.367	0.4	
	0.318	0.31			0.348	0.385	
J3	0.329	0.362	6050	H1	0.347	0.372	4800
	0.315	0.344			0.364	0.383	
	0.316	0.333			0.364	0.383	
	0.329	0.345			0.347	0.372	
	0.329	0.357			0.346	0.359	
J2	0.329	0.345	6050		0.345	0.351	
	0.316	0.333			0.362	0.372	
	0.317	0.32					
	0.329	0.331					

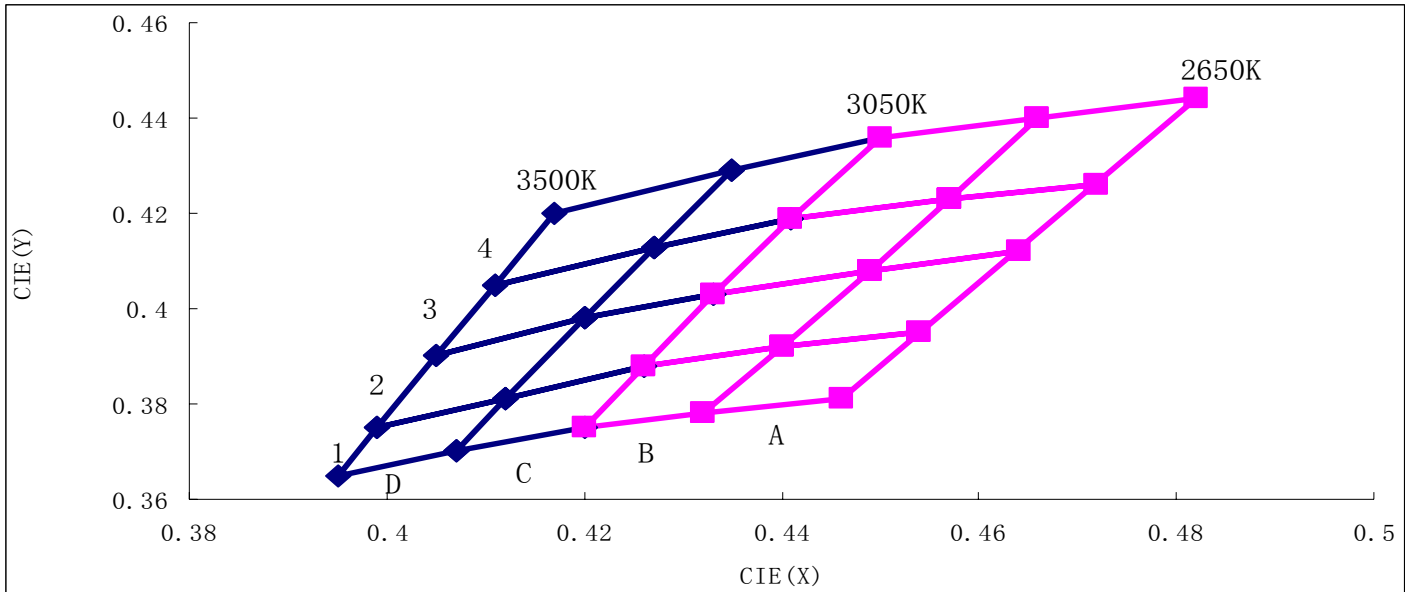

BIN	CHR-X	CHR-Y	TC (K)	BIN	CHR-X	CHR-Y	TC (K)
D4	0.435	0.429	3375	B4	0.466	0.44	2950
	0.417	0.42			0.45	0.436	
	0.411	0.405			0.441	0.419	
	0.427	0.413			0.457	0.423	
D3	0.427	0.413	3375	B3	0.457	0.423	2950
	0.411	0.405			0.441	0.419	
	0.405	0.39			0.433	0.403	
	0.42	0.398			0.449	0.408	
D2	0.42	0.398	3375	B2	0.449	0.408	2950
	0.405	0.39			0.433	0.403	
	0.399	0.375			0.426	0.388	
	0.412	0.381			0.44	0.392	
D1	0.412	0.381	3375	B1	0.44	0.392	2950
	0.399	0.375			0.426	0.388	
	0.395	0.365			0.42	0.375	
	0.407	0.37			0.432	0.378	
C4	0.45	0.436	3250	A4	0.482	0.444	2750
	0.435	0.429			0.466	0.44	
	0.427	0.413			0.457	0.423	
	0.441	0.419			0.472	0.426	
C3	0.441	0.419	3150	A3	0.472	0.426	2750
	0.427	0.413			0.457	0.423	
	0.42	0.398			0.449	0.408	
	0.433	0.403			0.464	0.412	
C2	0.433	0.403	3150	A2	0.464	0.412	2750
	0.42	0.398			0.449	0.408	
	0.412	0.381			0.44	0.392	
	0.426	0.388			0.454	0.395	
C1	0.426	0.388	3150	A1	0.454	0.395	2750
	0.412	0.381			0.44	0.392	
	0.407	0.37			0.432	0.378	
	0.42	0.375			0.446	0.381	

BIN	CHR-X	CHR-Y	TC (K)	BIN	CHR-X	CHR-Y	TC (K)
G3	0.38	0.4	4325	F1	0.387	0.374	3985
	0.365	0.389			0.372	0.364	
	0.362	0.373			0.369	0.35	
	0.376	0.382			0.382	0.358	
G2	0.376	0.382	4325	E3	0.417	0.42	3660
	0.362	0.373			0.398	0.411	
	0.359	0.356			0.392	0.391	
	0.372	0.364			0.409	0.4	
G1	0.372	0.364	4325	E2	0.409	0.4	3660
	0.359	0.356			0.392	0.391	
	0.356	0.341			0.387	0.374	
	0.369	0.35			0.402	0.382	
F3	0.398	0.411	3985	E1	0.402	0.382	3660
	0.38	0.4			0.387	0.374	
	0.376	0.382			0.382	0.358	
	0.392	0.391			0.396	0.367	
F2	0.392	0.391	3985				
	0.376	0.382					
	0.372	0.364					
	0.387	0.374					

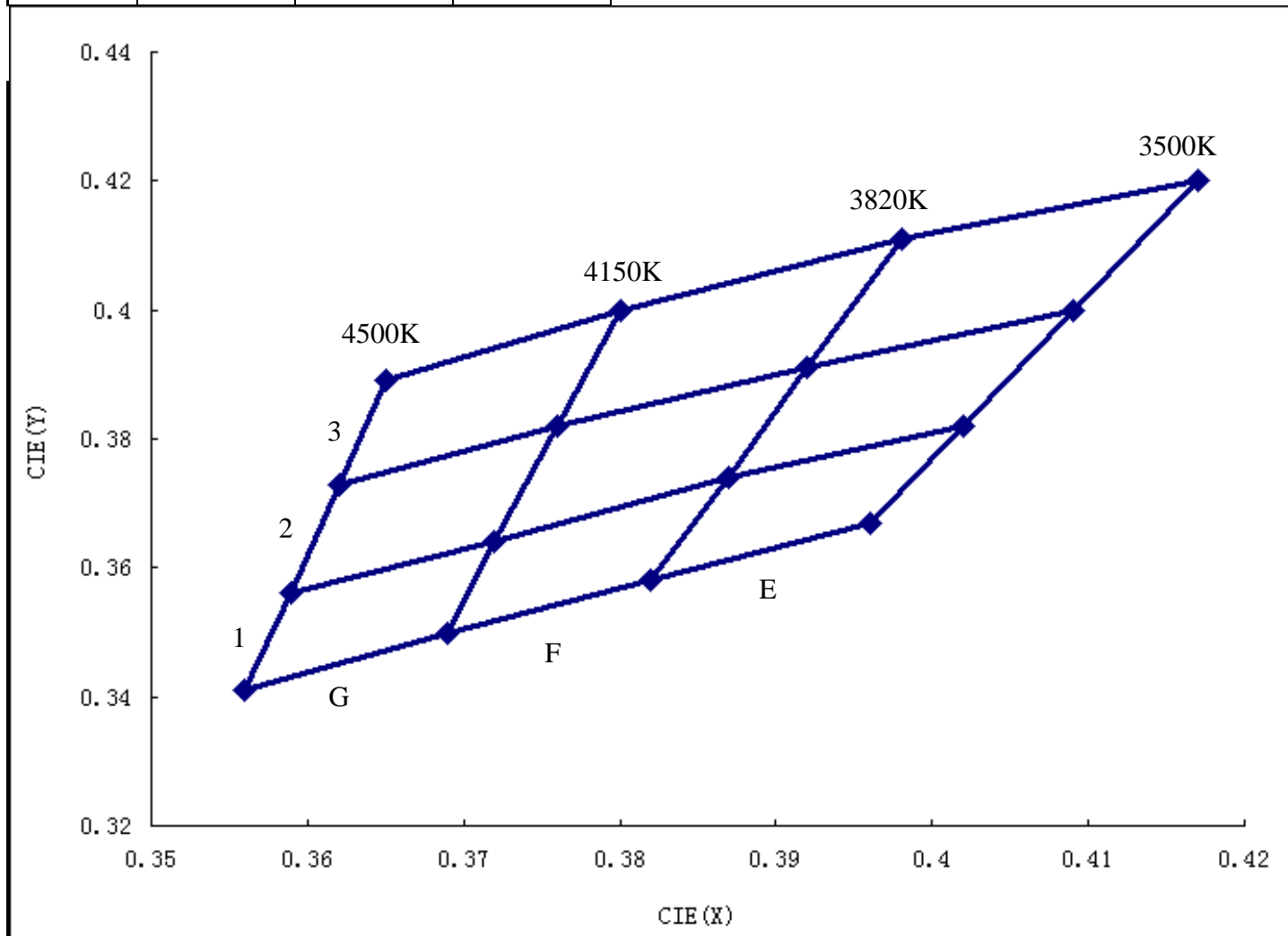

Standard Order Ranks:**White**

Code	TC		IV(Lm)	VF(V)
AW1	2500K-3500K	ABCD1-4	100-130---	3.0-4.5
AW2	3500K-4500K	EFG1-3	100-130---	3.0-4.5
AW3	5000K-7000K	I1 I2 I3 J1 J2 J3 K1 K2 K3	130-170---	3.0-4.5
AW4	7000k-10000k	LM1	100-130---	3.0-4.5

Red

Code	IV(Lm)	λd (nm)	VF(V)
RJ1	27-36---	620-630	1.8-2.8

Green

Code	IV(Lm)	λd (nm)	VF(V)
HG1	130-170---	515-525	3.0-4.5

Blue

Code	IV(Lm)	λd (nm)	VF(V)
AB1	27-36---	460-470	3.0-4.5

Yellow

Code	IV(Lm)	λd (nm)	VF(V)
YJ1	27-36---	585-595	1.8-2.8

Recommended Solder pad

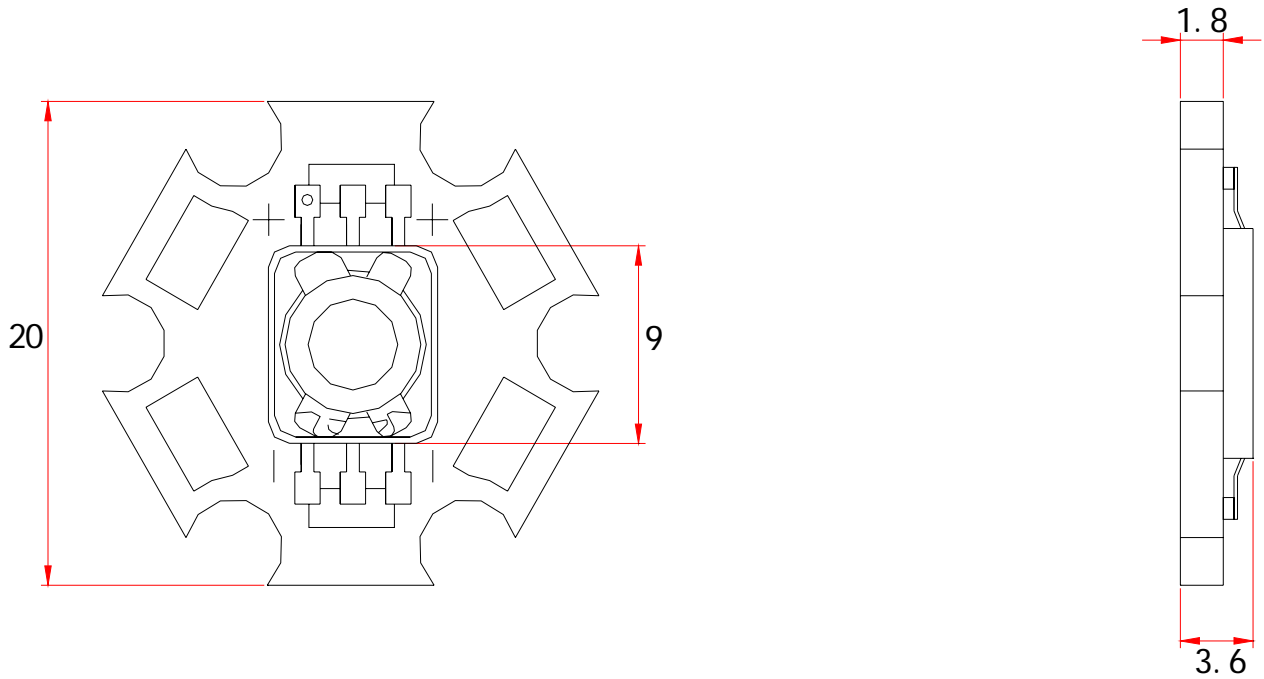

Note :

1. All dimensions are in millimeters
2. Scale none
3. This drawing without tolerances are for reference only

Hand Soldering conditions

Lead : Not more than 3 seconds @MAX280°C

Slug : Use a thermal-adhesives

* Caution

No second soldering recommended

Precaution for use

- Storage

In order to avoid the absorption of moisture, it is recommended to store in the dry box (or desiccator) with a desiccant . Otherwise, to store them in the following environment is recommended.

Temperature : 5℃~30℃ Humidity : 60%HR max.

- Attention after opened

However LED is correspond SMD, when LED be soldered dip, interfacial separation may affect the light transmission efficiency, causing the light intensity to drop. Attention in followed.

a. After opened and mounted, the soldering shall be quickly.

b. Keeping of a fraction

Temperature : 5 ~ 40℃ Humidity : less than 30%

- In case of more than 1 week passed after opening or change color of indicator on desiccant components shall be dried 10-12hr. at 60±5℃.

- In case of supposed the components is humid, shall be dried dip-solder just before. 100Hr at 80±5℃ or 12Hr at 100±5℃.

- Any mechanical force or any excess vibration shall not be accepted to apply during cooling process to normal temp. after soldering.

- Quick cooling shall avoid.

- Components shall not be mounted on warped direction of PCB.

- Anti radioactive ray design is not considered for the products listed here in.

- Gallium arsenide is used in some of the products listed in this publication. These products are dangerous if they are burned or smashed in the process of disposal. It is also dangerous to drink the liquid or inhale the gas generated by such products when chemically disposed.

- This device should not be used in any type of fluid such as water, oil, organic solvent and etc. When washing is required, IPA should be used.

- When the LEDs are illuminating, operating current should be decided after considering the package maximum temperature.

- LEDs must be stored to maintain a clean atmosphere. If the LEDs are stored for 3 months or more after being shipped from WW, a sealed container with a nitrogen atmosphere should be used for storage.

- The LEDs must be soldered within seven days after opening the moisture-proof packing.

- Repack unused products with anti-moisture packing, fold to close any opening and then store in a dry place.

- The appearance and specifications of the product may be modified for improvement without notice.

- Long time exposure of sunlight or UV occasions discolorment of PKG

Handling of Silicone resin LEDs

WAHWANG LED is encapsulated by silicone resin for the highest flux efficiency.

Notes for handling of Silicone resin WAHWANG LEDs

- Avoid touching silicone resin parts especially by sharp tools such as Pincette(Tweezers)

- Avoid leaving fingerprints on silicone resin parts.

- Dust sensitivity silicone resin need containers having cover for storage.

- When populating boards in SMT production, there are basically no restrictions regarding the form of the pick and place nozzle, except that mechanical pressure on the surface of the resin must be prevent.

This is assured by choosing a pick and place nozzle which is larger than the LEDs silicone resin area

- Please do not force over 3000 gf impact or pressure diagonally on the silicon lens. It will cause fatal damage of this product
