

CUSTOMER: P/N: 2380.072 REV. APPROVED BY:

REVISIONS		
REV.	DESCRIPTION	DATE
△		05.10.08
△		07.10.10
△		09.07.13
△		2010/06/21
△		2011/04/12
△		2012/02/29
△	Update head printing	2014/11/14

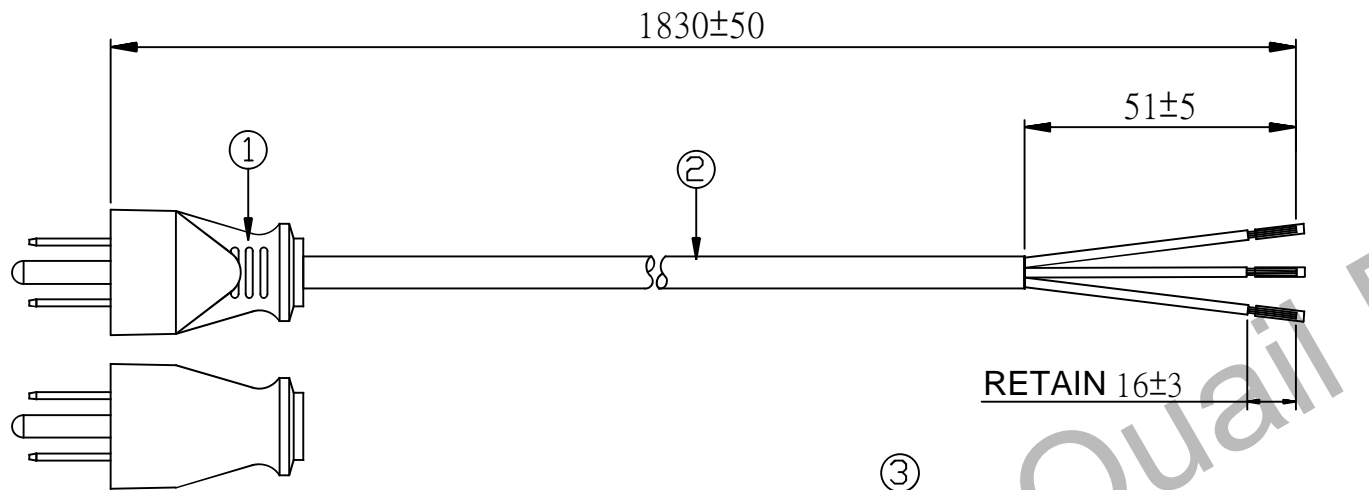

NOTES:
1. RoHS

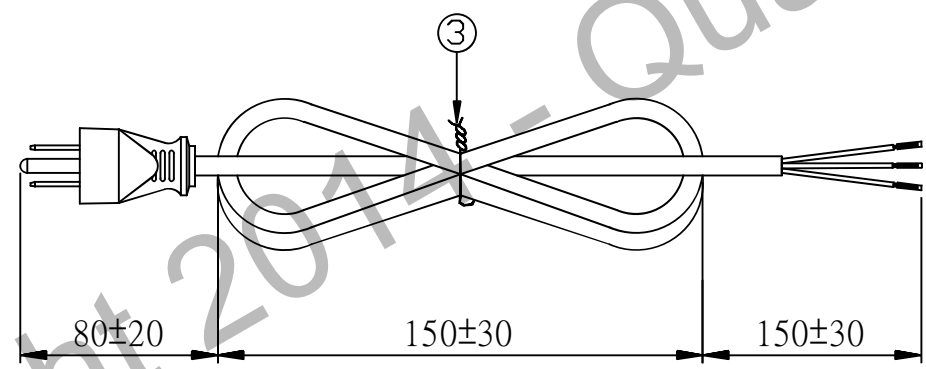
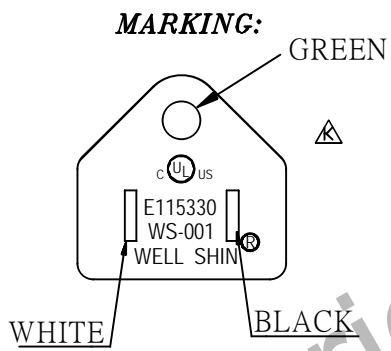

NEMA 5-15P

③	Cable tie	BLACK	1		SIGNATURE	 QUAIL ELECTRONICS, INC. http://www.quail.com
②	SVT 18AWG*3C 105°C ,APPROVAL :UL,C-UL(CSA)	BLACK	1	SAFETY ENGINEER:		
①	WS-001 10A/125V ,APPROVAL :UL,C-UL	BLACK	1	MANAGER BY:		
ITEM	DESCRIPTION	COLOR	Q'TY	CHECKED BY:		
					DRAWN BY:	
						PRODUCT NO.: 001 DATE: 2014/11/14 UNIT: mm SHEET: 1 OF 1 REV: K DWG NO: 0096-0023