

RoHS Compliant

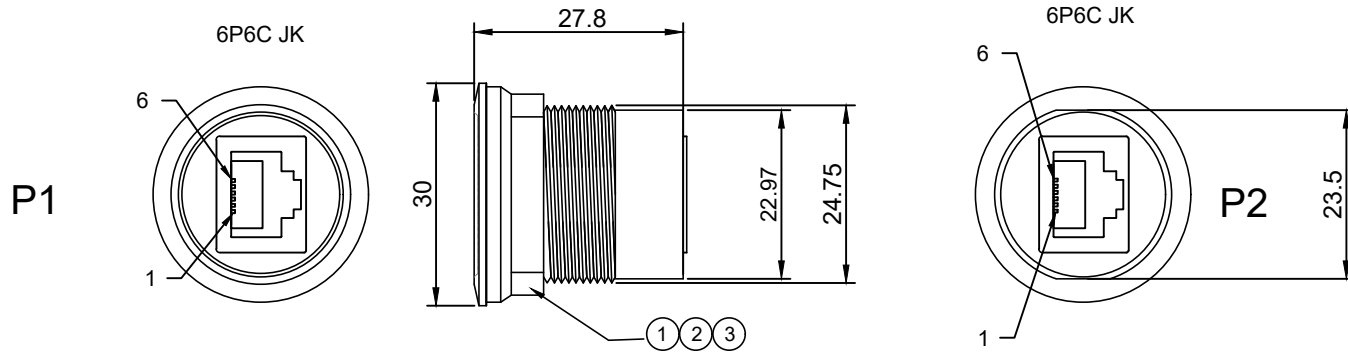

PIN ASSIGNMENT

P1		P
1-----		1
2-----		2
3-----		3
4-----		4
5-----		5
6-----		6
S-----		S

NOTES:
 1. PIN ASSIGNMENT SEE TO WIRE LIST.
 2. ELECTRICAL TEST CONDITION:
 (a).100%OPEN,SHORT & MISWIRE TEST,
 (b). INSULATOR RESISTANCE:10 Mohm MIN.
 DC 300V 0.01sec.
 (c). CONTACT RESISTANCE:3ohm MAX.

3	NUT BLACK PVC 27P MOLDED.	
2	PVC 45P BLACK.	
1	6P6C JACK BLACK PBT WITH NICKLE PLATED SHELL.	
NO.	Description	P/N

DWG NO:	PCM-0524	GOODS CODE		Draw	James	Date	2023/6/15
ITEM NO.		DRAWING EVIDENCE		Check		Date	
Goods NO.				Approval		Date	
Original NO.		Unit(mm)					

PREMIER CABLE MFG CO LTD			D		
			C		
			B		
			VER.A	REVISE	Date.